

CAD FILE:

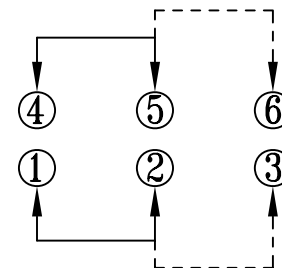

SCHEMATIC(NON-SHORTING)

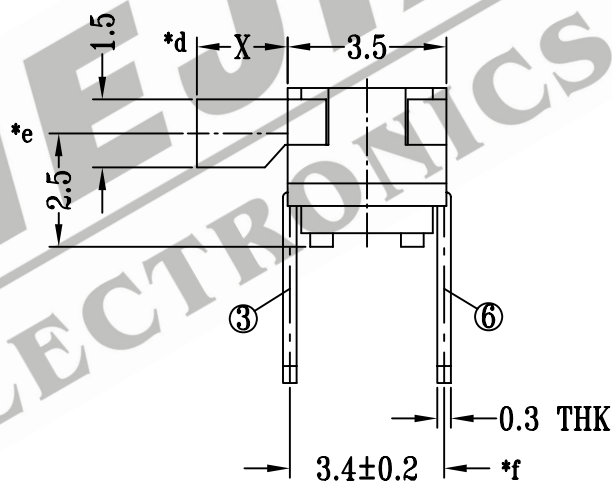
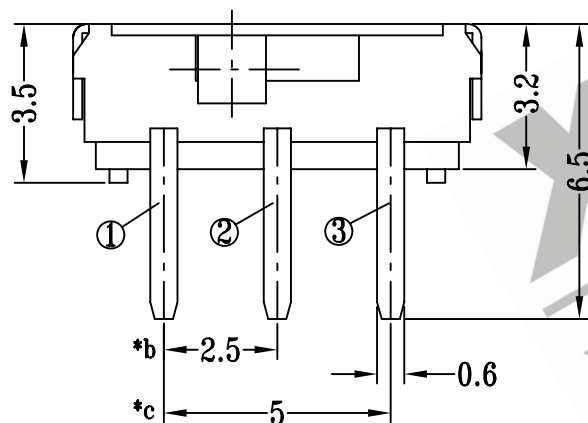
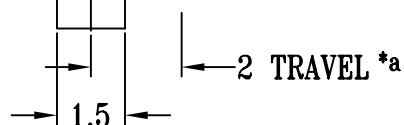
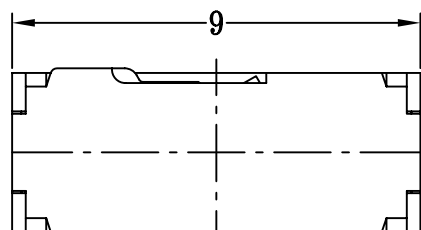
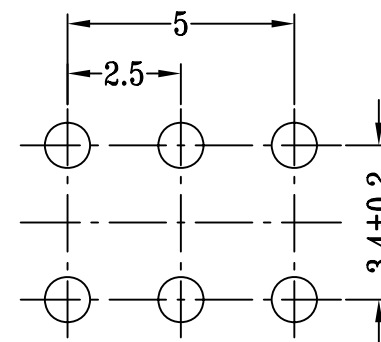

P.C.B LAYOUT

注:带"*"表示关键尺寸(6个)

8					TOLERANCE	SHENZHEN XIEJIA ELECTRONICS CO.,LTD.					
7					UNLESS SPECIFIED						
6					WITHIN : 1.5±0.1mm						
5					OVER : 1.5±0.2mm	ISSUE	DATE	DESCRIPTIONS OF REVISION	APPD.		
4	CONTACT	PBS	2	Ag CLAD	TITLE : MINI SLIDE SWITCH			UNIT : mm	DRWG NO.: XJ-DR-MK22D10-00		
3	CASE	NYLON46/BRASS STRIP	1	BLACK/Ag PLATED	MODEL: MK-22D10			SCALE: 6:1	DWN.	ZHOUYU	2002-4-27
2	KNOB	NYLON	1	WHITE					CHK'D	FANGYING	2002-4-27
1	COVER	SUS	1	WASHING					APPD.	KANGXINAN	2002-4-27
NO.	PARTS	MATERIALS	Q'TY	FINISH	ALL MATERIALS MUST BE COMPLIANT TO ROHS						